

VITA 31.2 200x Task Group

The development of a standard defining implementation of StarFabric in a VME64x form factor, leveraging PICMG 2.17 fabric boards and signal integrity studies

VITA 31.2 200x Task Group - Initial Activity

- Task Group was proposed at VSO November 2003
- Task Group was formed with 3 sponsors, 5 participants, and 2 observers signed up
- Initial draft has been created by the Sponsor Companies and will be distributed for review

VITA 31.2 200x Task Group - Purpose

To rapidly develop a VITA-31.x StarFabric specification that defines backplane, payload board, and switch board requirements that are compatible with VME64X backplanes, the VITA 31.0 specification, and the StarFabric Protocol Specification. This proposed standard will promote interoperability between new generations of StarFabric enabled products for the VME64x platform.

VITA 31.2 200x Task Group - Scope

The specification will define switched, high-speed point-to-point connectivity among some or all slots using StarFabric interconnect, with provisions for optional redundancy. StarFabric provides a solution for next-generation embedded equipment vendors, who want to utilize open standard technology, by offering capabilities such as high performance, scalability, high availability and quality-of-service at a relatively low cost. It is compatible with existing PCI software, drivers, O/S and hardware infrastructure so that adopters can maintain existing investments while solving next-generation challenges.

VITA 31.2 200x Task Group – Scope (continued)

The StarFabric VITA-31.X specification will define the following features/requirements:

- ◆ P0 connector StarFabric pinout for VME node boards based on the PICMG 2.17 specification for P3 pinout on Node slots
- ◆ Fabric slot pinout based on the PICMG 2.17 specification
- ◆ Fabric slot and board mechanics
- ◆ Signal routing requirements for LVDS signals on the backplanes and boards
- ◆ System management requirements
- ◆ (Optional) User Reserved pinouts for non-StarFabric I/O signals such as Ethernet (e.g. VITA 31.1) and Serial ports.
- ◆ Example topologies including:
 - ◆ Single Star
 - ◆ Dual Star

VITA 31.2 200x Task Group Organization

- Three Initial Supporting VSO Members (Sponsors):
 - ◆ Hybricon
 - ◆ StarGen
 - ◆ DNA Computing Solutions
- Task Group Members To Date:
 - ◆ Bob Sullivan, Hybricon Corporation Sponsor / Interim Chair
 - ◆ Steve Christo, StarGen, Inc. Sponsor / Interim Draft Editor
 - ◆ Keith Seawright, DNA Computing Solutions, Inc. Sponsor
 - ◆ Stewart Dewar, DY4 Participant
 - ◆ Melissa Heckman, Bustronic Corporation Participant
 - ◆ Andreas Lenkisch, Schroff GmbH Participant
 - ◆ John Rynearson, VITA Participant
 - ◆ Michael Thompson, Pentair Electronic Packaging Participant
 - ◆ Gorky Chin, VISTA Controls Corporation Observer
 - ◆ Brian Klein, Open Systems Publishing Observer

VITA 31.2 200x Task Group - P0 Connector Initial Pin-out

Connector Position	Connector Row						
	Z	a	b	c	d	e	f
1	GND						GND
2	GND						GND
3	GND						GND
4	GND						GND
5	GND						GND
6	GND						GND
7	GND						GND
8	GND						GND
9	GND						GND
10	GND	GND	GND	GND	GND	GND	GND
11	GND	LINK1_Tx3+	LINK1_Tx3-	GND	LINK1_Rx3+	LINK1_Rx3-	GND
12	GND	LINK1_Tx2+	LINK1_Tx2-	GND	LINK1_Rx2+	LINK1_Rx2-	GND
13	GND	LINK1_Tx1+	LINK1_Tx1-	GND	LINK1_Rx1+	LINK1_Rx1-	GND
14	GND	LINK1_Tx0+	LINK1_Tx0-	GND	LINK1_Rx0+	LINK1_Rx0-	GND
15	GND	LINK0_Tx3+	LINK0_Tx3-	GND	LINK0_Rx3+	LINK0_Rx3-	GND
16	GND	LINK0_Tx2+	LINK0_Tx2-	GND	LINK0_Rx2+	LINK0_Rx2-	GND
17	GND	LINK0_Tx1+	LINK0_Tx1-	GND	LINK0_Rx1+	LINK0_Rx1-	GND
18	GND	LINK0_Tx0+	LINK0_Tx0-	GND	LINK0_Rx0+	LINK0_Rx0-	GND
19	GND	GND	GND	GND	GND	GND	GND

VITA 31.2 200x Task Group - Initial Pin-out Fabric Slots

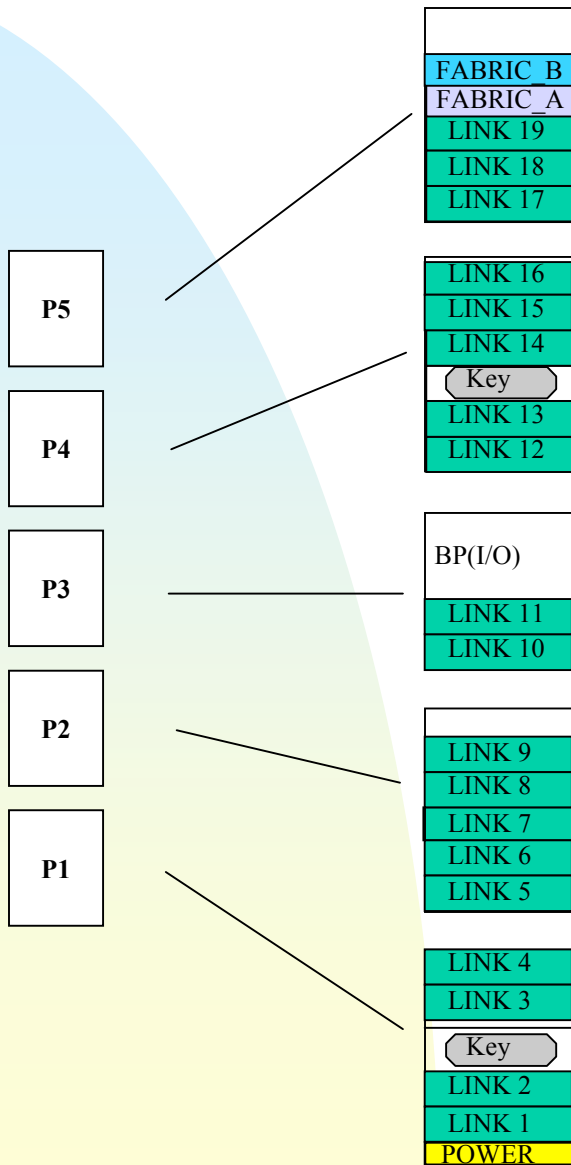

- Fabric Slots/Boards use 2mm connectors with identical pin-out to PICMG 2.17
- This allows existing PICMG 2.17 Switch Fabric boards to be used as-is in a VITA 31.2 system

VITA 31.2 200x Task Group - Initial Activity

- Initial Draft Standard will be sent out to the Task Group for review
- Initial task group conference call will be setup in the near future
 - ◆ Elect permanent chair and draft editor
 - ◆ Review initial draft
 - ◆ Plan timeline for completion